



### Differential Positive ECL (DPECL) HS-A2870 Series

#### Description

The **HS-A2870 Series** of quartz crystal oscillators provide MECL 10K and 10KH series compatible signals in industry standard four-pin DIP hermetic package. Systems designers may now specify space-saving, cost-effective packaged PECL oscillators to meet their timing requirements. This device is intended to operate on positive voltage for PECL applications.

#### Features

- Wide frequency range—15.0MHz to 250.0MHz
- User specified tolerance available
- Will withstand vapor phase temperatures of 253°C for 4 minutes maximum
- Space-saving alternative to discrete component oscillators
- High shock resistance, to 3000g
- 3.3 Volt operation
- Metal lid electrically connected to ground to reduce EMI
- Low Jitter
- MECL 10K and 10KH series compatible output on Pin 8, complement on Pin 1
- High Q Crystal actively tuned oscillator circuit
- Power supply decoupling internal
- No internal PLL avoids cascading PLL problems
- High frequencies due to proprietary design
- Gold plated leads - Solder dipped leads available upon request
- RoHS Compliant, Lead Free Construction (unless solder dipped leads are supplied)
- COTS/Dual use

#### Electrical Connection

Pin	Connection
1	Output Complement
7	V <sub>EE</sub> /Ground
8	Output
14	V <sub>CC</sub>

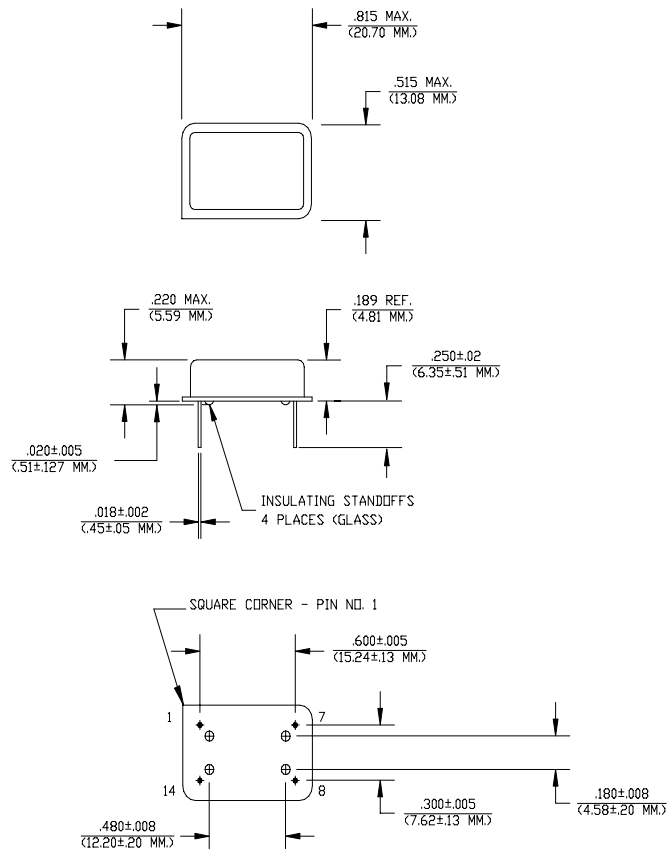

Dimensions are in inches and (MM)

### HS-A2870 Series Continued Differential Positive ECL (DPECL)

### Operating Conditions and Output Characteristics

#### Electrical Characteristics

Parameter	Symbol	Conditions	Min	Typical	Max
Frequency	-----	-----	15.0MHz	-----	250.0MHz
Duty Cycle	-----	@V <sub>CC</sub> -1.29V	45/55%	-----	55/45%
Logic 0 <sup>(2)</sup>	V <sub>OL</sub>	-----	V <sub>CC</sub> -1.95V	-----	V <sub>CC</sub> -1.60V
Logic 1 <sup>(2)</sup>	V <sub>OH</sub>	-----	V <sub>CC</sub> -1.02V	-----	V <sub>CC</sub> -0.74V
Rise & Fall Time	tr,tf	20-80%V <sub>O</sub> with 50 ohm load to V <sub>CC</sub> -2V	-----	1.0 ns	1.5 ns
Tpd <sup>(4)</sup>	-----	-----	-0.5 ns	-----	+0.5 ns
Jitter, RMS <sup>(3)</sup>	-----	-----	-----	-----	5 psec
Frequency Stability <sup>(1)</sup>	dF/F	Overall conditions including: voltage, calibration, temp., 10 yr aging, shock, vibration	-100ppm	-----	+100ppm

#### General Characteristics

Parameter	Symbol	Conditions	Min	Typical	Max
Supply Voltage	V <sub>CC</sub>	-----	3.15V	3.3V	3.45V
Supply Current	I <sub>CC</sub>	50 ohm termination To 2.00V below V <sub>CC</sub>	0.0 mA	-----	80 mA
Output current	I <sub>O</sub>	Low level Output Current	0.0 mA	-----	±50.0 mA
Operating temperature	T <sub>A</sub>	-----	0°C	-----	70°C
Storage temperature	T <sub>S</sub>	-----	-55°C	-----	125°C
Power Dissipation	P <sub>D</sub>	-----	-----	-----	276 mW
Lead temperature	T <sub>L</sub>	Soldering, 10 sec.	-----	-----	300°C
Load	50 Ohm to V <sub>CC</sub> -2V or Thevenin Equivalent, Bias Required	-----	-----	-----	-----
Start-up time	t <sub>s</sub>	-----	-----	2 ms	10 ms

#### Environmental and Mechanical Characteristics

Mechanical Shock	Per MIL-STD-202, Method 213, Condition E
Thermal Shock	Per MIL-STD-883, Method 1011, Condition A
Vibration	0.060" double amplitude 10 Hz to 55 Hz, 35g's 55Hz to 2000 Hz
Soldering Condition	300°C for 10 seconds
Hermetic Seal	Leak rate less than 1 x 10 <sup>-8</sup> atm.cc/sec of helium
ESD Sensitivity	Human Body Model per ON Semiconductor 10kH series ECL: 500V min.

#### Footnotes:

- 1) Standard frequency stability (±20,±25,±50ppm & others available)
- 2) V<sub>OL</sub>, V<sub>OH</sub>, referenced to ground (V<sub>EE</sub>) with V<sub>CC</sub> = 3.3V
- 3) Jitter performance is frequency dependent. Please contact factory for full characterization.  
RMS jitter bandwidth of 12kHz to 20MHz.
- 4) Tpd is phase shift between the falling edge of pin 8 at V<sub>CC</sub>-1.29V and rising edge of pin 1 at V<sub>CC</sub>-1.29V.

Creating a Part Number	
<b>HS - A287X - FREQ</b>	
<b>Package Code</b>	<b>Tolerance/Performance</b>
HS Ledged 4 pin (14 pin)	0 ±100ppm 0-70°C
SM Ledged 4 pin (14 pin) SMD	1 ±50ppm 0-70°C
Gull Wing	7 ±25ppm 0-70°C
<b>Input Voltage</b>	9 Customer Specific
Code Specification	A ±20ppm 0-70°C
A 3.3V	B ±50ppm -40 to +85°C
5V	C ±100ppm -40 to +85°C

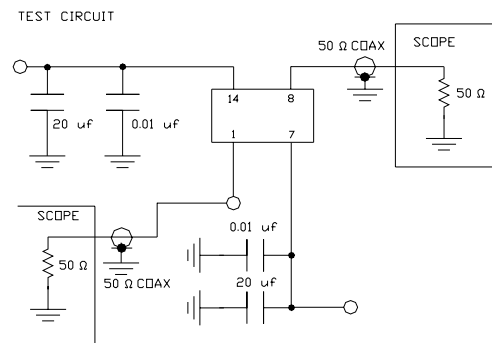

TEST CIRCUIT USES A SPLIT SUPPLY OF +2V AND -1.3V FOR EASE OF TESTING.